

# CRUISER 1060



*Our experience*

*Your key to success*

**KEESTRACK**

MOBILE CRUSHING AND SCREENING EQUIPMENT



**KEESTRACK**  
MOBILE CRUSHING AND SCREENING EQUIPMENT

*Our experience  
Your key to success*



## *Applications*

- Granite, Basalt and all medium and hard stone
- Concrete and landfill recycling
- Primary crushing
- Construction waste
- Demolition
- Quarrying
- Gravel
- Coal

Optimum flexibility and mobility with the highest possible performance

Low cost solution that offers superior crushing results

State of the art KeeTrack crusherbox

Free standing machine without support legs

Robust design with reasonable machine weight

Top quality components being used

Full automatic feeding system

Compact transport dimensions

Low feeding height

Quick set-up time

Proven reliability



# TECHNICAL SPECIFICATIONS:

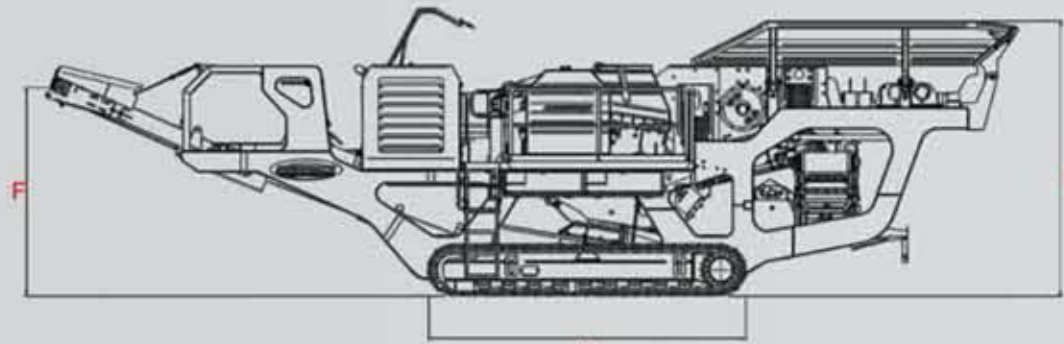
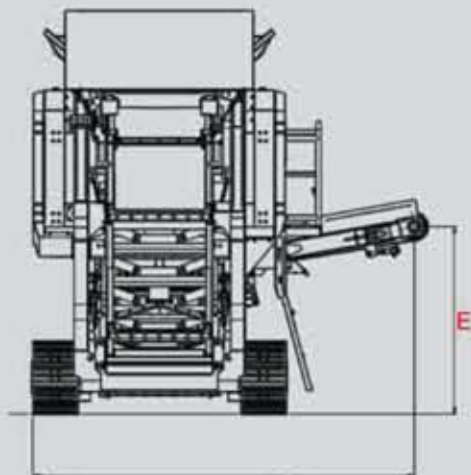
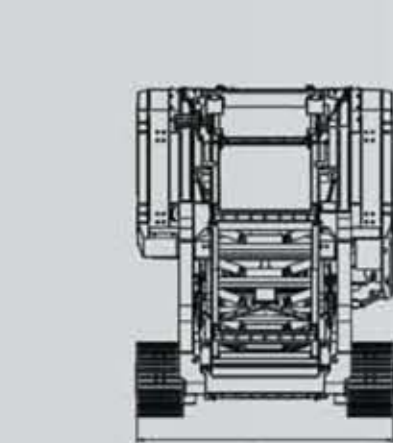
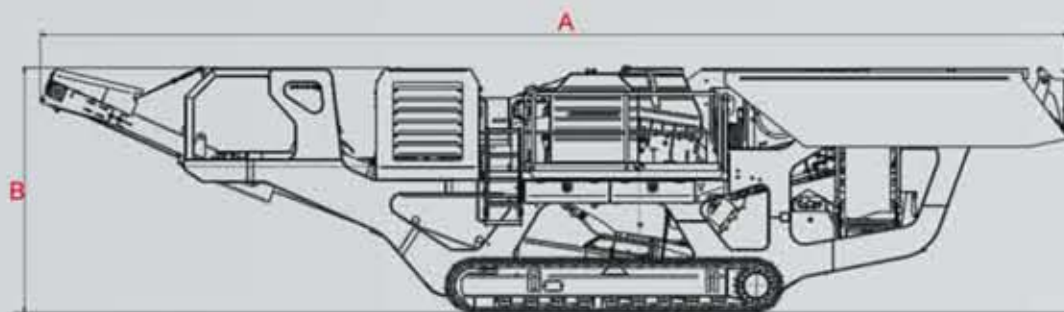

A	B	C	D	E	F	G	H	
13468	3214	2512	3778	1056	2894	3812	4425	mm
44' 2"	10' 7"	8' 3"	12' 5"	3' 6"	9' 6"	12' 6"	14' 6"	ft inch

Transport height	:3200 mm	10,6"
Transport width	:2550 mm	8'4"
Transport weight	:appr. 32T.	70,548 pounds

## Pos.1) Feed Hopper

- Capacity	:ca. 6m <sup>3</sup>	7,84 yards
- Hopperwall plates	:Hardox 400 anti abrasive steel	
- Back load width	:2500 mm	8'2"
- Side load width	:4000 mm	13'2"
- Loading height	:3400 mm	11'2"

## Pos.2) Vibrating Feeder

- Model	: GT1000	
- Length	:2300 mm	7'7"
- Width	:1000 mm	3'3"
- Variable Speed	:adjustable 0-900 rpm	
- Capacity	:up to 300 tons/hour	
- Drive	:11 kW hydraulic motor	15 hp

## Pos.3) Grizzly Screen

- Grizzly screen	:2300 mm x 1000 mm, with openings 40mm, punched plate	7'7" x 3'3" 1,6"
- Bottom deck	:1700mm x 1000 mm square mesh, according customer's requirement	5'7" x 3'3"

## Pos.4) Under screen conveyor

- Length	:1400 mm	4'7"
- Width	:800 mm	2'6"
- Speed	:2,09 m/sec	
- Max. Capacity	:150 t/h	
- Drive	hydraulic 5 kW	7 hp
- Reversible belt to feed the prescreened material under the crusher or to the side conveyor		

## Pos.5) Jaw Crusher

- Model	:1000 mm x 600 mm	3'3" x 1'12"
- Feed opening	:600 mm high x 1000 mm wide	1'12" x 3'3"
- Weight	:14 250 kg	31415 pounds
- Speed	:280 rpm	
- Jaw plates	:907 kg/pc reversible	
- Settings	:40 mm until max. 150 mm	1,6" - 5,9"

## Pos.6) Main output conveyor

- Length	:8500 mm	27'11"
- Width	:900 mm	2'11"
- Max. capacity	:250 t/h	
- Speed	:1,15 m/s	
- Drive	:Hydraulic motor 15 kW	21 hp

## Pos.7) Track-unit

- Model	:BERCO D4e	
- Length	:3800 mm	12'6"
- Width (total)	:2550 mm	8'4"
- Width of the tracks	:450 mm	1'6"
- Max speed	:1 km/h	0,7 mile/h

# CRUISER 1060

## OPTIONS LIST

1. Waterpump
2. Radio remote control
3. Diesel fill pump 80 l / min
4. Working lamps (3)
5. Overband magnet
6. Hardox lining in the Hopper



1



2



3



4



5



6

Powered with:



### RATINGS AND FUEL CONSUMPTION

bph	bkw	rpm	gr/kw/h	Emissions regulations
230	168	1800	220	TIER 3



## Our Experience

### Your key to success

The material in this document is for information only and is subject to change without notice. Keestrack N.V. assumes no liability resulting from errors or omissions in this document, or from the use of the information contained herein.

Les renseignements contenus dans ce document ne sont fournis qu'à titre d'information uniquement et peuvent être modifiés sans avis préalable. Keestrack N.V. décline toute responsabilité résultant d'erreurs ou d'omissions dans ce document, ou de l'utilisation des renseignements y figurant.

Este documento es sólo para informativos y su contenido puede cambiar sin aviso previo. Keestrack N.V. no se hace responsable de los errores u omisiones en este documento ni de los daños ocasionados por el uso de la información contenida en el mismo.

Der Inhalt dieses Dokuments ist nur zur Information bestimmt und kann ohne vorherige Bekanntgabe geändert werden. Keestrack N.V. übernimmt für Fehler oder Auslassungen oder für die Anwendung der enthaltenen Informationen keine Haftung.

Il materiale contenuto in questo depliant è solamente a titolo informativo e può essere cambiato senza alcun preavviso. Keestrack N.V. non assume responsabilità per eventuali errori od omissioni o per l'uso delle informazioni contenute.

De gegevens in dit document zijn alleen ter informatie bedoeld en kunnen ten alle tijde zonder verwittiging veranderd worden. Keestrack N.V. is niet verantwoordelijk voor eventuele drukfouten, onvolledigheden of voor het gebruik van de informatie in deze folder.

**Head office:**  
Keestrack nv  
Taunusweg 2  
3740 Bilzen - Belgium  
Tel: +32 89 51 58 51  
info@keestrack.net  
marketing3@keestrack.net  
www.keestrack.com

Tridic s.r.o.  
Piskovište 3  
Šternberk - Czech Republic  
Tel: +420 585 002 031  
marketing2@keestrack.net  
www.tridic.com

Keestrack of America  
3550 Fairfield Road  
Baltimore MD 21226 USA  
Tel: +1 410 355 1377  
sparesusa@keestrack.net

Keestrack (Chuzhou) Construction  
Equipment Co., Ltd  
Add: Cheng Dong Industry Park,  
Chuzhou, Anhui 239000, P.R.C  
Tel: +86 (0) 550 365 25 05  
sales.asia1@keestrack.net  
www.keestrackchina.com

Keestrack Technology Center Ltd  
Vasna Road  
Arjun Heights, 3th Floor  
Vadodara 390 015 - India  
Tel: +91 265 225 2682  
info@keestrack-ktc.com

**KEESTRACK**  
MOBILE CRUSHING AND SCREENING EQUIPMENT